

Chain No.	G	L	F	G ₁	L ₁	W ₁	E ₁	E ₂	d ₄
	mm	mm	mm	mm	mm	mm	mm	mm	mm
P200F74	167.0	130.0	41.5	60.0	30.0	23.0	8.0	12.0	8.0
P200F132	168.0	127.0	44.3	63.0	27.0	26.0	7.0	7.0	8.0
P200F156	167.0	130.0	41.2	60.0	30.0	23.0	8.0	12.0	8.0
P200F177	170.0	127.0	48.0	62.0	27.0	26.0	7.0	7.0	7.0
P203.2F2	170.0	127.0	39.0	62.0	27.0	24.0	6.8	10.8	6.5

Chain No.	节距 Pitch	滚子直径 Roller diameter	内节内宽 Width between inner plates	销轴直径 Pin diameter	销轴长度 Pin length	链板高度 Plate depth	链板厚度 Plate thickness	抗拉强度 Tensile strength	平均抗拉强度 Average tensile strength	每米长重 Weight per meter
	P	d _{1 max}	b _{1 min}	d _{2 max}	L _{c max}	h _{2 max}	T _{max}	Q _{min}	Q ₀	q
	mm	mm	mm	mm	mm	mm	mm	kN/bf	kN	kg/m
P200F74	200.0	50.0	24.0	11.9	62.0	30.0	6.0	100/22480	110.0	6.1
P200F132	200.0	50.0	25.5	14.0	63.0	35.0	6.0	130/29225	143.0	7.1
P200F156	200.0	50.0	23.0	11.9	62.0	32.0	6.3	100/22480	110.0	6.4
P200F177	200.0	60.0	26.0	18.0	75.0	45.0	8.0	230/51704	241.5	11.8
P203.2F2	203.2	50.5	24.0	11.0	64.6	32.0	6.0	120/26977	130.0	6.2

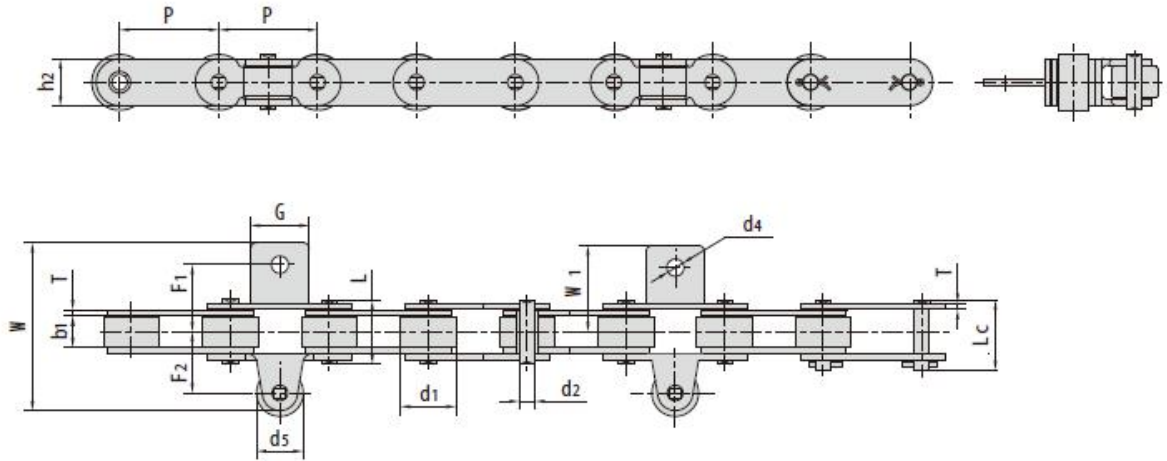

Chain No.	G	F ₁	F ₂	W ₁	W	d ₄	d ₅
	mm	mm	mm	mm	mm	mm	mm
C 2082F35	30.0	33.0	32.0	45.7	86.7	8.8	24.0
C 2082HF70	30.0	34.0	32.0	44.0	85.0	8.6	24.0
C 2082F78	30.0	28.5	32.0	45.7	86.7	8.8	24.0

Chain No.	节距 Pitch	滚子直径 Roller diameter	内节内宽 Width between inner plates	销轴直径 Pin diameter	销轴长度 Pin length		链板高度 Plate depth	链板厚度 Plate thickness	抗拉强度 Tensile strength	平均抗拉强度 Average tensile strength	每米长重 Weight per meter
	P	d _{1 max}	b _{1 in}	d _{2 max}	L _{max}	L _{c max}	h _{2 max}	T _{max}	Q _{min}	Q ₀	q
	mm	mm	mm	mm	mm	mm	mm	mm	kN/bf	kN	kg/m
C 2082F35	50.8	28.58	15.75	7.92	32.7	36.5	24.0	3.25	55.6/12500	60.0	3.37
C 2082HF70	50.8	28.58	15.75	7.92	36.2	38.9	24.0	4.00	55.6/12500	60.0	3.31
C 2082F78	50.8	28.58	15.75	7.92	32.7	36.5	24.0	3.25	55.6/12500	60.0	3.37

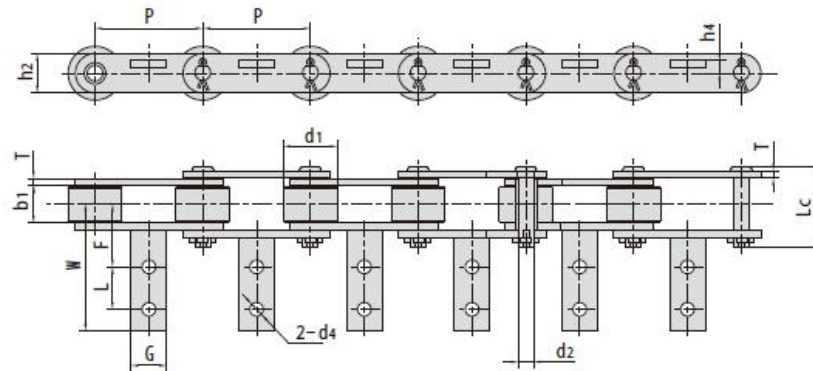

Chain No.	G	L	F	W	h4	d4
	mm	mm	mm	mm	mm	mm
P76.2F30	25.0	31.8	44.5	89.8	9.0	9.7

Chain No.	节距 Pitch	滚子直径 Roller diameter	内节内宽 Width between inner plates	销轴直径 Pin diameter	销轴长度 Pin length	链板高度 Plate depth	链板厚度 Plate thickness	抗拉强度 Tensile strength	平均抗拉强度 Average tensile strength	每米长重 Weight per meter
	P	d1 max	b1 min	d2 max	Lc max	h2 max	T max	Q _{min}	Q ₀	q
	mm	mm	mm	mm	mm	mm	mm	kN/bf	kN	kg/m
P76.2F30	76.2	38.0	24.0	11.0	55.0	28.7	5.0	75/16860	80.0	5.67

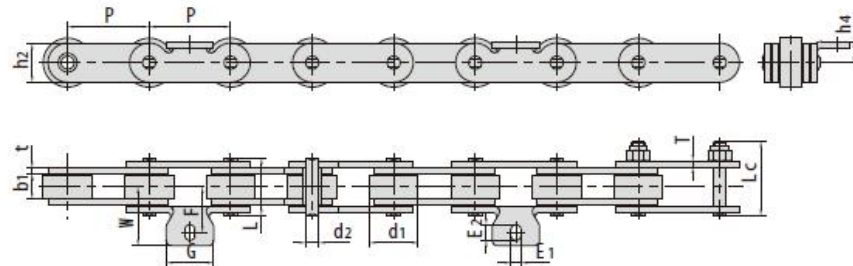

Chain No.	G	F	W	h4	E1	E2
	mm	mm	mm	mm	mm	mm
P50F46	29.0	27.5	36.5	13.0	6.2	9.5

Chain No.	节距 Pitch	滚子直径 Roller diameter	内节内宽 Width between inner plates	销轴尺寸 Pin dimension			链板高度 Plate depth	链板厚度 Plate thickness	抗拉强度 Tensile strength	平均抗拉强度 Average tensile strength	每米长重 Weight per meter
	P	d1 max	b1 min	d2 max	L max	Lc max	h2 max	t/T max	Q _{min}	Q ₀	q
	mm	mm	mm	mm	mm	mm	mm	mm	kN/bf	kN	kg/m
P50F46	50.0	30.0	14.5	8.0	35.5	45.6	24.0	4.0	50/11240	55.0	3.73

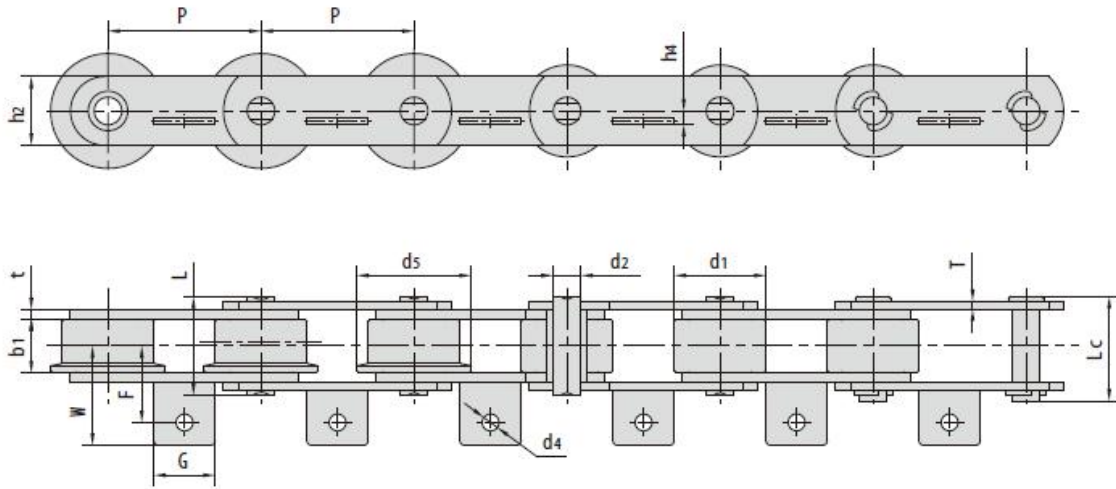

Chain No.	G	F	W	h ₄	d ₄
	mm	mm	mm	mm	mm
P 100F74	40.0	55.00	73.0	8.0	12.0
P 100F171	40.0	55.00	73.5	10.0	12.0
P 100F173A1	40.0	47.25	64.3	9.5	11.0
P 100F260A1	40.0	55.00	73.0	8.0	12.0
P 160F104A1	50.0	64.00	99.0	15.0	13.0

Chain No.	节距 Pitch	滚子直径 Roller diameter		内节内宽 Width between inner plates	销轴直径 Pin diameter		销轴长度 Pin length		链板高度 Plate depth	链板厚度 Plate thickness	抗拉强度 Tensile strength	平均抗拉强度 Average tensile strength	每米长重 Weight per meter
	P	d _{1 max}	d _{5 max}	b _{1 min}	d _{2 max}	L _{max}	L _{c max}	h _{2 max}	t/T _{max}	Q _{min}	Q ₀	q	
	mm	mm	mm	mm	mm	mm	mm	mm	mm	kN/bf	kN	kg/m	
P 100F74	100.0	60.0	-	34.0	18.0	-	69.0	45.0	6.0/5.0	140/31470	150.0	13.80	
P 100F171	100.0	60.0	-	35.0	18.0	65.0	69.5	41.0	6.0/5.0	140/31470	150.0	13.17	
P 100F173A1	100.0	60.0	75.0	36.0	18.0	65.0	70.5	45.0	6.0/5.0	140/31470	150.0	16.10	
P 100F260A1	100.0	60.0	-	34.0	18.0	-	63.0	45.0	4.0	120/26977	130.0	11.20	
P 160F104A1	160.0	80.0	96.0	48.0	25.0	95.5	102.0	65.0	10.0/8.0	315/70812	330.7	28.30	

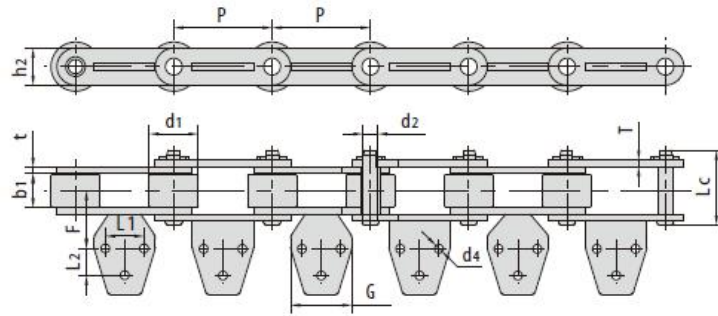

Chain No.	G	F	L1	L2	d4
	mm	mm	mm	mm	mm
P76.2F63A3	47.5	44.7	30.0	21.0	6.7

Chain No.	节距	滚子直径	内节内宽	销轴尺寸		链板高度	链板厚度	抗拉强度	平均抗拉强度	每米长重
	Pitch	Roller diameter	Width between inner plates	Pin diameter	Pin dimension	Plate depth	Plate thickness	Tensile strength	Average tensile strength	Weight per meter
	P	d1 max	b1 min	d2 max	Lc max	h2 max	t/T max	Qmin	Qo	q
	mm	mm	mm	mm	mm	mm	mm	kN/bf	kN	kg/m
P76.2F63A3	76.2	38.1	25.2	11.0	57.0	28.7	5.0	80/17984	88.0	7.10

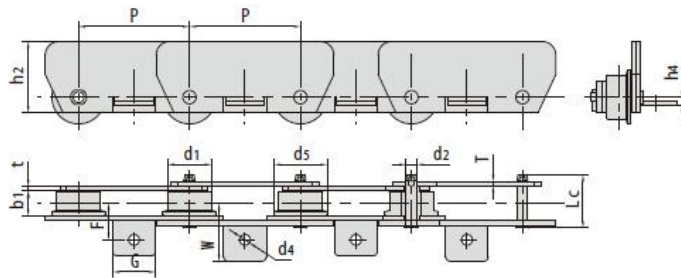

Chain No.	G	F	W	h4	d4
	mm	mm	mm	mm	mm
M80F36A1-F-125	48.0	41.0	65.0	9.0	12.0

Chain No.	节距	滚子直径		内节内宽	销轴直径		链板高度	链板厚度	抗拉强度	平均抗拉强度	每米长重
	Pitch	d1 max	d5 max	Width between inner plates	d2 max	Lc max	Plate depth	Plate thickness	Tensile strength	Average tensile strength	Weight per meter
	P	d1 max	d5 max	b1 min	d2 max	Lc max	h2 max	t/T max	Qmin	Qo	q
	mm	mm	mm	mm	mm	mm	mm	mm	kN/bf	kN	kg/m
M80F36A1-F-125	125.0	50.0	60.0	28.0	12.0	60.0	80.0	5.0	80/17984	88.0	12.50

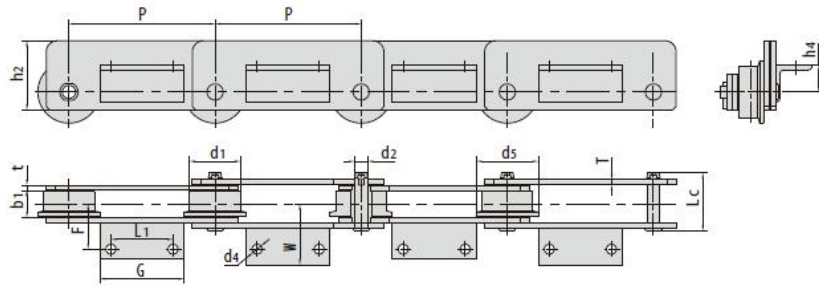

Chain No.	G	L1	F	W	h4	d4
	mm	mm	mm	mm	mm	mm
M 160F57A2-F-200	115.0	85.0	62.0	83.3	36.0	13.5

Chain No.	节距 Pitch	滚子直径 Roller diameter	内节内宽 Width between inner plates	销轴尺寸 Pin dimension		链板高度 Plate depth	链板厚度 Plate thickness	抗拉强度 Tensile strength	平均抗拉强度 Average tensile strength	每米长重 Weight per meter	
	P	d1 max	b1 min	d2 max	Lc max	h2 max	t/T max	Q min	Q0	q	
	mm	mm	mm	mm	mm	mm	mm	kN/bf	kN	kg/m	
M 160F57A2-F-200	200.0	70.0	90.0	37.0	18.0	80.0	95.0	7.0	160/15968	172.8	18.80

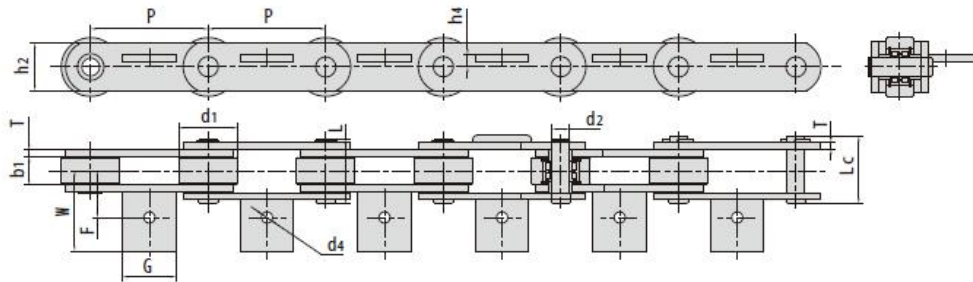

Chain No.	G	F	W	h4	d4
	mm	mm	mm	mm	mm
P200F33	90.0	79.0	136.0	21.5	14.0

Chain No.	节距 Pitch	滚子直径 Roller diameter	内节内宽 Width between inner plates	销轴直径 Pin diameter	销轴长度 Pin length		链板高度 Plate depth	链板厚度 Plate thickness	抗拉强度 Tensile strength	平均抗拉强度 Average tensile strength	每米长重 Weight per meter
	P	d1 max	b1 min	d2 max	L max	Lc max	h2 max	T max	Q min	Q0	q
	mm	mm	mm	mm	mm	mm	mm	mm	kN/bf	kN	kg/m
P200F33	200.0	100.0	48.0	30.0	107.0	112.0	80.0	12.0	648/145670	680.0	37.8