

不锈钢推窗防弯链

Stainless steel Anti-sidebow chains for pushing window

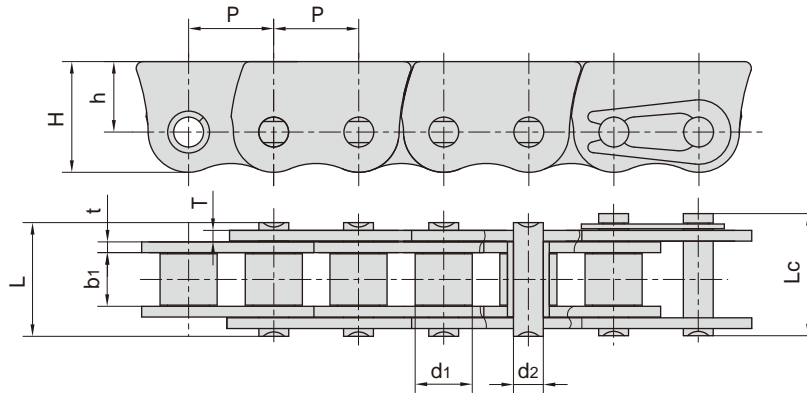

| Chain No. | 节距<br>Pitch | 滚子直径<br>Roller diameter | 内节内宽<br>Width<br>between<br>inner plates | 销轴直径<br>Pin diameter | 销轴长度<br>Pin length | 链板尺寸<br>Plate dimension |       |           | 抗拉强度<br>Tensile strength | 每米长重<br>Weight per meter |
|-----------|-------------|-------------------------|--|----------------------|--------------------|-------------------------|-------|-----------|--------------------------|--------------------------|
|           | P           | d1 max                  | b1 min                                   | d2 max               | L max              | H max                   | h     | t/T max   | Q min                    | q                        |
|           | mm          | mm                      | mm                                       | mm                   | mm                 | mm                      | mm    | mm        | kN/lbf                   | kg/m                     |
| 06BF33SS  | 9.525       | 6.35                    | 5.72                                     | 3.28                 | 13.15              | 12.38                   | 7.88  | 1.30      | 6.2/1394                 | 0.63                     |
| 06BF40SS  | 9.525       | 6.35                    | 5.72                                     | 3.28                 | 13.15              | 12.38                   | 7.88  | 1.30      | 6.2/1394                 | 0.63                     |
| *06CF49SS | 9.525       | 5.08                    | 4.77                                     | 3.58                 | 14.80              | 13.20                   | 8.80  | 2.03      | 8.0/1799                 | 0.89                     |
| *06CF51SS | 9.525       | 5.08                    | 4.77                                     | 3.58                 | 12.80              | 13.20                   | 8.80  | 2.03/1.00 | 7.0/1574                 | 0.69                     |
| 08BSSF20  | 12.700      | 8.51                    | 7.75                                     | 4.45                 | 16.70              | 16.50                   | 10.50 | 1.60      | 12.0/2698                | 1.06                     |
| 08BF66SS  | 12.700      | 8.51                    | 7.75                                     | 4.45                 | 18.80              | 14.30                   | 8.50  | 2.03      | 12.0/2698                | 1.07                     |
| 08BSSF74  | 12.700      | 8.51                    | 7.75                                     | 4.45                 | 18.80              | 15.50                   | 9.70  | 2.03/1.85 | 13.0/2922                | 1.19                     |

\*套筒链：表中滚子直径d1为套筒直径

\*Bush chain: d1 in the table indicates the external diameter of the bush.

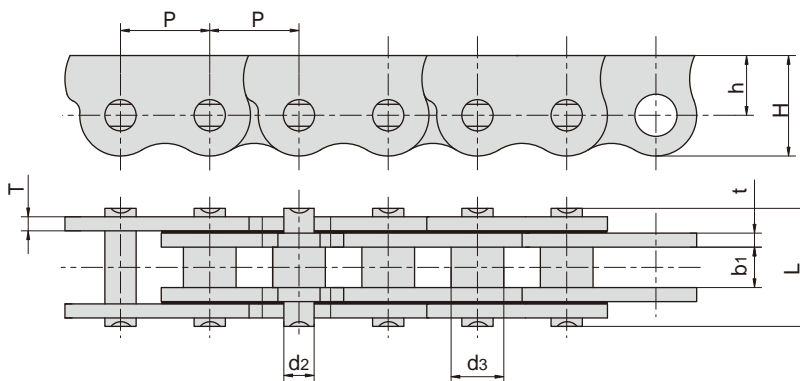

| Chain No. | 节距<br>Pitch | 内节内宽<br>Width<br>between<br>inner plates | 销轴直径<br>Pin diameter |        | 销轴长度<br>Pin length | 链板尺寸<br>Plate dimension |      |         | 抗拉强度<br>Tensile strength |
|-----------|-------------|--|----------------------|--------|--------------------|-------------------------|------|---------|--------------------------|
|           | P           | b1 min                                   | d2 max               | d4 max | L max              | H max                   | h    | t/T max | Q min                    |
|           | mm          | mm                                       | mm                   | mm     | mm                 | mm                      | mm   | mm      | kN                       |
| 06CF31SS  | 9.525       | 4.50                                     | 3.58                 | 5.08   | 11.50              | 12.40                   | 7.90 | 1.30    | 5.2/1169                 |
| P12.7F3SS | 12.700      | 5.50                                     | 4.45                 | 7.50   | 15.60              | 14.30                   | 8.90 | 2.03    | 12.0/2698                |

不锈钢推窗防弯链

Stainless steel Anti-sidebow chains for pushing window

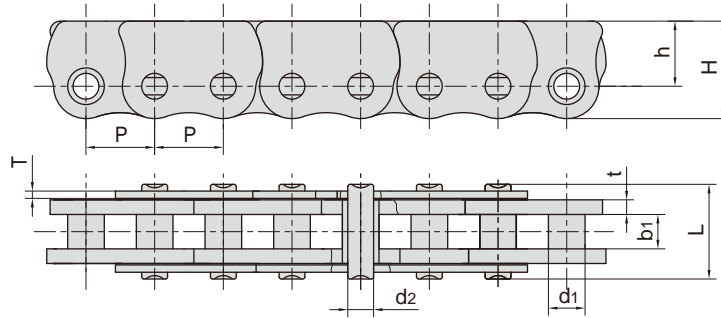

| Chain No. | 节距<br>Pitch | 套筒直径<br>Bush diameter | 内节内宽<br>Width between inner plates | 销轴直径<br>Pin diameter | 销轴长度<br>Pin length | 链板尺寸<br>Plate dimension |      |           | 抗拉强度<br>Tensile strength |
|-----------|-------------|-----------------------|------------------------------------|----------------------|--------------------|-------------------------|------|-----------|--------------------------|
|           | P           | d1 max                | b1 min                             | d2 max               | L max              | H max                   | h    | t/T max   | Q min                    |
|           | mm          | mm                    | mm                                 | mm                   | mm                 | mm                      | mm   | mm        | kN                       |
| 06CF51SS  | 9.525       | 5.08                  | 4.77                               | 3.58                 | 12.80              | 13.20                   | 8.80 | 1.00/2.03 | 7.0/1574                 |

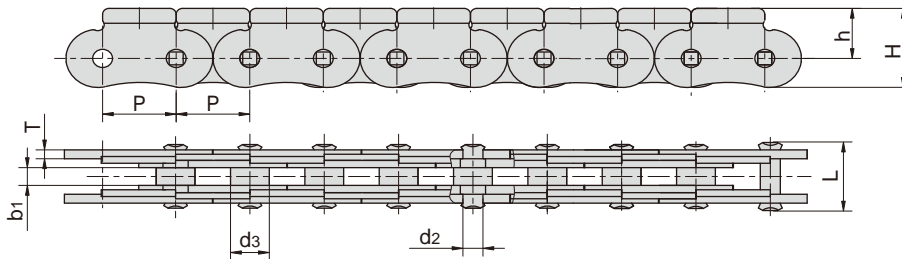

| Chain No. | 节距<br>Pitch | 内节内宽<br>Width between inner plates | 销轴直径<br>Pin diameter |        | 销轴长度<br>Pin length | 链板尺寸<br>Plate dimension |      |       | 抗拉强度<br>Tensile strength |
|-----------|-------------|------------------------------------|----------------------|--------|--------------------|-------------------------|------|-------|--------------------------|
|           | P           | b1 min                             | d2 max               | d3 max | L max              | H max                   | h    | T max | Q min                    |
|           | mm          | mm                                 | mm                   | mm     | mm                 | mm                      | mm   | mm    | kN                       |
| P11.5SS   | 11.500      | 3.00                               | 3.00                 | 6.00   | 108.0              | 13.50                   | 8.50 | 1.50  | 5.5/1236                 |

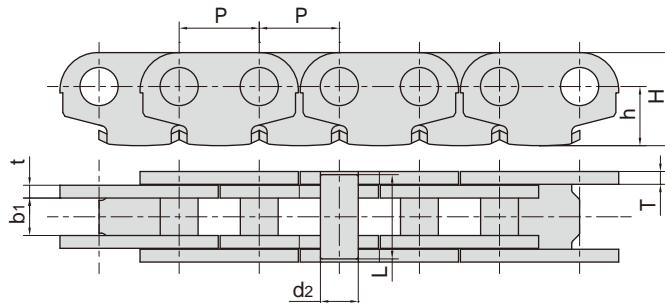

| Chain No.    | 节距<br>Pitch | 内节内宽<br>Width between inner plates | 销轴直径<br>Pin diameter | 销轴长度<br>Pin length | 链板尺寸<br>Plate dimension |      |      | 抗拉强度<br>Tensile strength | 每米长重<br>Weight per metr |
|--------------|-------------|------------------------------------|----------------------|--------------------|-------------------------|------|------|--------------------------|-------------------------|
|              | P           | b1 min                             | d2 max               | L max              | H max                   | h    | t/T  | Q min                    | q                       |
|              | mm          | mm                                 | mm                   | mm                 | mm                      | mm   | mm   | kN                       | kN/m                    |
| P12.7F14SBSS | 12.70       | 5.94                               | 6.00                 | 13.40              | 14.76                   | 9.38 | 2.03 | 10.0/2248                | 0.89                    |