

## 不锈钢空心销轴输送链 (MC系列)

Stainless steel hollow pin conveyor chains (MC series)

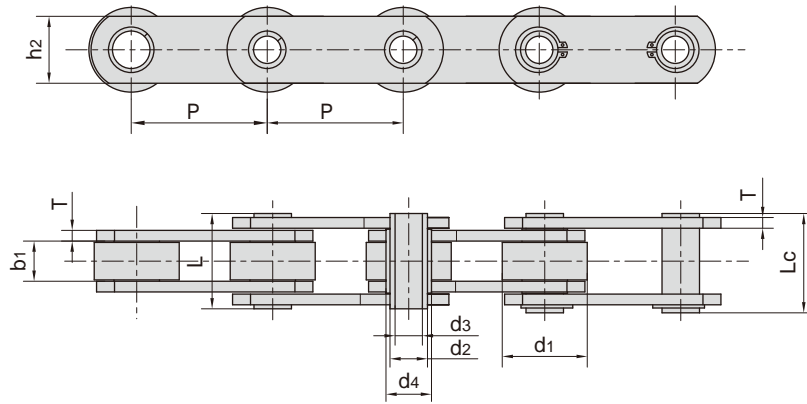

无滚子  
without rollers

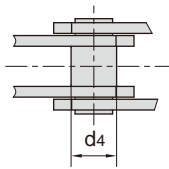

带S型小滚子  
with S small rollers type

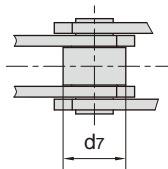

带P型大滚子  
with P large rollers type

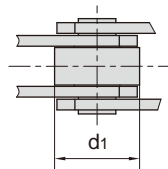

带F型带肩滚子  
with F flanged rollers type

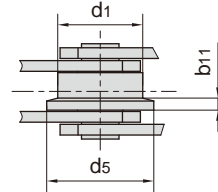

Chain No.	节距 Pitch					滚子尺寸 Roller dimension				套筒直径 Bush diameter	链板高度 Plate depth
	P					d1 max	d7 max	d5 max	b11	d4 max	h2 max
	mm					mm	mm	mm	mm	mm	mm
MC28SS	63.0	80.0	100.0	125.0	160.0	36.0	25.0	45.0	4.5	17.5	2.5
MC56SS	80.0	100.0	125.0	160.0	200.0	50.0	30.0	60.0	5.0	21.0	35.0
MC112SS	100.0	125.0	160.0	200.0	-	70.0	42.0	85.0	7.0	29.0	50.0
MC224SS	160.0	200.0	-	-	-	100.0	60.0	120.0	10.0	41.0	70.0

东华链号 Donghua Chain No.	内节内宽 Width between inner plates	销轴直径 Pin diameter		销轴长度 Pin length		链板厚度 Plate thickness	抗拉强度 Tensile strength
	b1 min	d2 max	d3 min	L max	Lc max	t/T max	Q min
	mm	mm	mm	mm	mm	mm	kN/lbf
MC28SS	20.0	13.0	8.2	36.0	38.5	3.5	28.0/6364
MC56SS	24.0	15.5	10.2	45.0	47.5	4.0	56.0/12727
MC112SS	32.0	22.0	14.3	62.5	64.3	6.0	112.0/25454
MC224SS	43.0	31.0	20.3	83.0	85.5	8.0	224.0/50909